

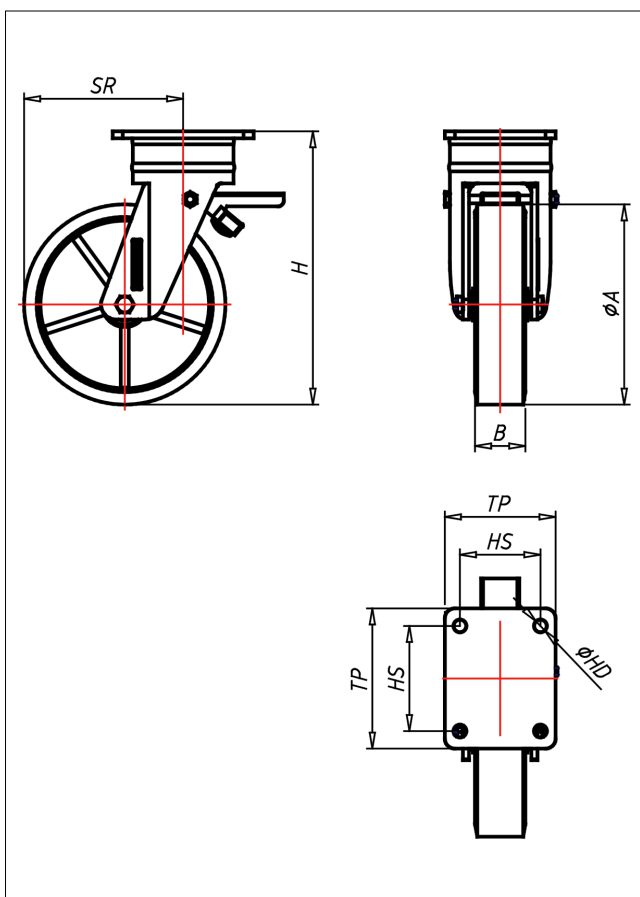

QDT-ZK/LZK

Lenkrolle mit Totalfeststeller



QD-Z



LENKROLLE	LENKROLLE MIT TOTALFESTSTELLER	BOCKROLLE																				
<ul style="list-style-type: none"> geräuscharmer Lauf geringer Rollwiderstand abrieb- und reißfest hohe Stoßfestigkeit sehr beständig gegen viele aggressive Medien <p>Guss-Polyurethan Felge Gusseisen lackiert → Seite 249</p>	<p>Schrägrollen- und Axialkugellager, staubgeschützt, sehr starker Zentralschrauben, Mütter gesichert, Schmiernippel Ausführung verzinkt → Seite 26</p>	<p>AUSWAHLHILFE:</p> <table border="1"> <tr> <td>leicht lenkend</td> <td>-</td> <td>+</td> <td>++</td> </tr> <tr> <td>verschleißarm</td> <td>-</td> <td>+</td> <td>++</td> </tr> <tr> <td>stoßfest</td> <td>-</td> <td>+</td> <td>++</td> </tr> <tr> <td>bodenschonend</td> <td>-</td> <td>+</td> <td>++</td> </tr> <tr> <td>witterungsbeständig</td> <td>-</td> <td>+</td> <td>++</td> </tr> </table>	leicht lenkend	-	+	++	verschleißarm	-	+	++	stoßfest	-	+	++	bodenschonend	-	+	++	witterungsbeständig	-	+	++
leicht lenkend	-	+	++																			
verschleißarm	-	+	++																			
stoßfest	-	+	++																			
bodenschonend	-	+	++																			
witterungsbeständig	-	+	++																			

Technische Details

ORDERNO (Artikel-nummer)	QDT 250 LZK
WDAB (Rad-Ø A x Breite B / mm)	250x60
LC (Tragkraft / kg)	1400
H (Bauhöhe H / mm)	318
TP (Plattengröße / mm)	140x110
HS (Lochabstand / mm)	105x80
HD (Loch-Ø / mm)	12.5
SR (Schwenkradius / mm)	195
WB (Radlager)	Kugellager